

Fibre optic hybrid broadcast camera systems

P. Longhurst and A. Brooks
LEMO Fibre Optic Unit of Research

© LEMO UK 2007



Fibre optic hybrid broadcast camera systems

Television companies typically have years of experience in using triax cable systems. When installing this type of cable in their studios they have adequate knowledge to pull in the cables and to terminate them simply and quickly with connectors they have been using for years, and with minimal copper cable tooling. A soldering iron is probably the most expensive piece of termination tooling they need.

Equally, testing the cable assemblies is relatively straightforward, and again uses relatively simple, inexpensive equipment. If a triax cable becomes defective, or a new one is needed quickly, it is a simple job to do. Indeed, if a cable is broken along its length a “fast and dirty” repair can be achieved in a very short space of time with simply a means of stripping the broken cable ends and a roll of insulation tape.

So it is little wonder that the migration to the new generation HDTV cameras that require the use of interconnecting hybrid fibre optic cables is viewed with some alarm as the perceptions are that:-

- 1. The hybrid fibre optic cable itself is more expensive than Triax cable.*
- 2. The hybrid fibre optic connectors are more expensive than Triax connectors*
- 3. The termination of this type of cable is more complex, and time consuming.*
- 4. The termination tooling required is much greater.*
- 5. The test equipment necessary to ensure that all is working correctly is more expensive.*
- 6. Contacts get dirty easily and are difficult to keep clean.*

In addition to the above, for a studio to be as independent with using hybrid fibre optic cabling as it is today with triax cabling, requires significant capital outlay and re-training of wiremen to be able to cope with the new technology.

Also the newer fibre optic interconnection system has achieved a poor operational reputation with some users, who have incorrectly perceived it as unreliable and very difficult (and therefore expensive) to maintain, mainly due to a lack of understanding and/or training, or due to the purchase of poor quality assemblies.

So what are the benefits of committing to this new technology?

HDTV picture quality is greatly superior to the very best that SDTV can offer, but for this improvement in performance there is a price to pay. To get the picture quality it is necessary for HDTV cameras to send a lot more data (1.458 Gb/s – SMPTE 292M) to the CCU than SDTV cameras (540Mb/s – SMPTE 344M), and this is only likely to increase.

If the transmission distance is short (<1000m), HDTV signals can be transmitted using digital grade RG-11/U type 75 ohm triax cable. For longer distances (e.g. O.B. use) a repeater is necessary, and these repeaters can be expensive (around \$18,500 each). However the use of such a repeater will allow a triax based HDTV camera to operate at a distances up to about 2000 metres maximum. (Note: this information is based on the sales literature for the Thompson Grass Valley LDK 6000 Mk II HDTV Camera).

Some HDTV camera manufacturers have decided to go almost exclusively for fibre-based systems (e.g. Sony, Ikegami, Arri) and, using locally powered cameras, the digital HDTV signal can be sent well over 20km (12 miles) of single mode fibre, without the need for a repeater. Where the cameras are powered over the hybrid cable from the CCU, distances of over 2 km are commonplace. The distance in this case is only limited by the voltage drop in the electrical power part of the hybrid cable assembly. In the event that distances greatly in excess of 2km are required special 12mm diameter “long haul” cable, with double the number of power conductors is available.

With regard to installations, equipping new studios, OB vans or sporting venues solely with triax limits the possibilities of the type / manufacturer of camera systems which could be used, whereas the installation of hybrid fibre cables gives an excellent level of “future-proofing”. The single mode fibres used in the ARIB / SMPTE hybrid cable



specification have a very high bandwidth (>100Ghz.km) which is much greater than required for today's HDTV systems. Any future camera developments can easily be accommodated using this type of fibre, which if multiplexed signals are used has practically limitless bandwidth. So where future HDTV cameras require the use of fibre, any triax-only studios/sports arenas are going to be at a severe disadvantage.

Having said that, it is recognised that maintenance and repair of the cable / connector infrastructure is of primary concern to users. Yes, fibre optic contacts do need to be inspected and kept clean, just like a camera lens, but maintenance is simply a matter of regular inspection, and cleaning when necessary.

If an O.B cable gets damaged, the best solution is to run out a spare factory terminated cable. However it is recognised that there are occasions when "field termination" might be needed, which can be provided by either pre-terminated contacts or fibre splicing.

Another major concern for Outside Broadcast is speed of deployment of cables that will "work first time" and not get damaged or fail in use. Key to this is the connector /cable combination, the security and reliability of the termination, and the ability of the connector to withstand rough handling. Factory terminated cable assemblies supplied on drums or in coils that can be concatenated together provide the ideal solution. Secure water proof end caps are essential to prevent dirt and water getting in to the unconnected ends, as with triax. Proper termination of the cable is essential to prevent water ingress and/or damage to fibre within the connector. Any connector that is filled with water will have problems if it is to handle power. Expanded beam fibre optic contacts are easier to clean but the benefits need to be traded off against higher inherent loss and the significantly fewer connections that can be made.

To answer the six points raised above:-

1. As with any new technology, the early days are bound to be the most expensive. Already the cost of the cable has dropped significantly since its introduction more than a decade ago as "economies of scale" begin to take effect. As more countries start to roll out HDTV, more cable manufacturers have joined the market for hybrid fibre optic HDTV cable, so competition will almost certainly drive the cable cost downwards even more.

In fact the difference in price between digital-grade RG-11/U triax cable and the hybrid fibre optic cable is very small (both around £3 - £6 per metre depending on quality).

The primary English language specification for HDTV broadcast cables is SMPTE 311M -1998, with 6 main manufacturers of the cable but each with varying properties. Some are more suited to indoor applications and some to the harsher outside broadcast environment, therefore it is very important that data sheets & test reports are examined before a cable is selected: i.e. for outside broadcast, tensile strength, crush resistance, abrasion and tear resistance and repeated bend/twist capability are all critical features, whereas for in building use greater flexibility and flame / smoke retardance are required.

Factors that affect cable reliability are:

- Extent of braid coverage - SMPTE states 82% which is probably too low for OB
- Fibre material - e.g. pvc jacketed vs. nylon jacketed.
- Cushioning material - polypropylene vs. cotton
- Cable manufacturing construction. Fibre is delicate and excessive movement within the cable can result in micro-bending of fibre and signal failure - good cable construction and materials is essential for reliability.

You get what you pay for!

2. The cost of a pair of triax connectors is around £100. The cost of a pair of SMPTE hybrid Fibre Optic connectors, including fibre optic contacts, is around £170.



3. The termination + test cost of a pair of triax connectors is around £110, and the cost to terminate + test a pair of SMPTE Hybrid fibre optic connectors is around £250. So when considered as part of a cable assembly the fibre optic connectors, due to their complexity, do cost more and are more expensive to terminate and test.

So at today's prices hybrid cables are between 30% and 60% more expensive than triax, but as they carry approximately 3 times more information than SD Triax cables they are still good value for money.

4. & 5. The tooling required to terminate hybrid connectors using the standard epoxy and polish contact is approximately £14K (comprising Polishing machine/jig @ £11,500, curing oven @ £500 and general tooling £2000 approx). The Fibre Optic test equipment costs approximately £13K (Loss test set, video inspection scope, OTDR, Return Loss meter).

Termination training courses are available from most of the connector manufacturers.

An alternative to epoxy and polish for terminations in the field or within the studio is the use of cleave and crimp pre-terminated fibre optic contacts. The tooling used for this repair is much less expensive (approximately £2000), and a single quick-repair connector can be fully terminated in approximately 45 minutes. The LEMO option has the benefit of being fully intermateable with the SMPTE global standard connector. However, crimp and cleave style contacts have a relatively short life and should really only be used as a "get out of trouble" repair, not a permanent solution. The cable should be fully re-terminated when time permits, either in-house with the full tooling and trained personnel or by sending the cable to a suitable termination house for repair.

A further option for site installations is to fusion splice laid-in cable to factory made patchcords - this requires a fusion splicer costing around £8000. For both the pre-terminated contact and fusion splice options it is beneficial to have fibre optic test equipment available as outlined above, though not absolutely necessary.

As stated earlier in some cases hybrid cable assemblies have somewhat unjustly earned a reputation for being unreliable. In fact most problems that arise can be attributed to the fibre optic ferrule endfaces becoming dirty (in much the same way as home video cassette recorders were sometimes replaced when the picture became unstable, simply because the video head needed cleaning).

Cleaning of the fibre optic ferrule endfaces on a butt joint ferrule is often said to be impossible, or at least difficult to do.

This is not true.

Most fibre optic connectors are designed to make the cleaning of the fibre optic contacts as easy as possible.

However many users are completely unaware that:

- a) The first rule is "inspect the endface and if it isn't dirty don't touch it"
- b) If the fibre is dirty it needs to be cleaned
- c) The cleaning process is simple and quick, with minimal tooling required.

Connector manufacturers should be able to recommend and / or provide the inspection and cleaning equipment needed, together with cleaning and inspection instructions.

To clean the "female" contact in a butt joint connector the alignment device or "adaptor" normally needs to be removed. For some manufacturers the alignment device is removed using standard tooling (e.g. screwdriver), but there is the risk that the alignment device can be dropped and either lost or contaminated, whilst other manufacturers offer special low cost tooling which retains the alignment device safely and also ensures that no unauthorised people can remove the alignment device.

There are a number of different connectors of varying styles that can be used in broadcast situations. However in fundamental design, few choices are available:

- Optical contacts can be either butt joint or lensed (expanded beam)
- Fibre retention in the optical contacts can be “Epoxy and polish” or utilise some form of mechanical splice behind a pre-terminated ferrule.
- Coupling mechanisms can be push – pull or screw / bayonet
- Connector shells can be plug and socket, or hermaphroditic
- Keying and the ability to easily “blind mate” is essential
- Standards are vital to ensure compatibility between product from different manufacturers.

A quick comparison between the various styles is as follows:

- Expanded beam contact.
 - + points: Cleaning simple with no special cleaning materials required.
Good back reflection results.
 - - points: More expensive.
More complicated to terminate.
Larger than other options.
High attenuation - limited number of connections per system feasible.
Not field repairable.
Not compatible with global standard.
- Butt joint, pre-terminated contact – 1.25mm ferrule.
 - + points: Good attenuation.
Good back reflection results.
Can be field terminated.
Push-pull for quick connection.
 - - points: High price.
Larger than other options.
Limited life - should only be used for emergency repair.
High yield.
Not compatible with global standard.
- Butt joint contact (Lemo 3K.93C)
 - + points : Excellent attenuation - multiple links feasible(e.g. 10 connections).
Good back reflection results.
Smallest size (compatible with cable diameter).
Simple to clean.
Proven reliability – global standard
Push-pull for quick connection.
 - - points: Could not be field terminated (until now).



In terms of size and performance the critical differences between the major makes of hybrid connectors currently available are as follows:

- Attenuation (typical)
 - LEMO 3K.93C:- 0.1dB ;
 - Stratos HX-1080 :- 0.75 dB
 - Fischer 1053:- 0.5dB

- Return loss (typical)
 - LEMO 3K.93C:- >45dB
 - Stratos HX-1080 :- >45dB
 - Fischer 1053:- > 50dB

- Size
 - LEMO 3K.93C:- 94mm long x 19.5mm dia
 - Stratos HX-1080:- 158mm long x 35mm dia
 - Fischer 1053:- > 101mm long x 23mm dia

- Mating endurance
 - LEMO 3K.93C:- >20,000 cycles
 - Stratos HX-1080:- >2,000 cycles
 - Fischer 1053:- > 500 cycles

(Note: all data above taken from the relevant manufacturer's published data sheet)

The LEMO 3K.93C connector was specifically designed and has been proven to meet all the requirements of all the ARIB, SMPTE and EBU Standards.

- *ARIB Technical Report BTA S -1005B: Interconnection for HDTV studio equipment*
- *SMPTE Standard SMPTE 304M-1998: Broadcast cameras - Hybrid Electrical and Fibre Optic Connector*
- *EBU Technical Recommendation R100 -1999: Connectors for camera cables with fibre optic transmission*
-

Cable standards have also been created (ARIB and SMPTE 311M) for the Broadcast market – for example Furukawa have been producing such cable for 10 years and are now the market leader in Japan, due to the quality and reliability of their cable.

With over 50,000 connectors having been employed globally over the last 10 years, the LEMO 3K.93C has a proven track record of use, from arctic to desert conditions and from sporting venues to studios.

If terminated according to LEMO's instructions 3K.93C using good quality cable, hybrid fibre assemblies will provide reliably consistent high performance in all broadcast situations.

In the event of damage to a cable a field repair option (pre-terminated contact) is available that will provide a temporary solution that operates close to the factory terminated specifications. This has the benefit of also being compatible with the global standard connectors.

For the future newly developed LEMO electro-optic converters allow existing Triax cameras to be used with hybrid fibre optic 3K.93C cable assemblies, reducing the immediate need to upgrade all cameras to fibre based cameras if new hybrid cabling infrastructure is installed.

In conclusion therefore, there are established standards for hybrid fibre connectors and cables, and, with attention to good termination and maintenance practice, broadcast users should not be afraid of the transfer to fibre optic hybrid interconnection systems for HD use.

Below are shown typical layouts for HDTV systems with recommended LEMO connector models

Outside Broadcast Van

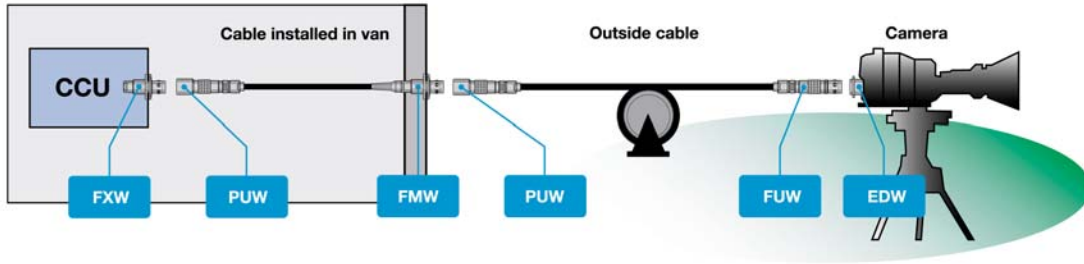

Stadium

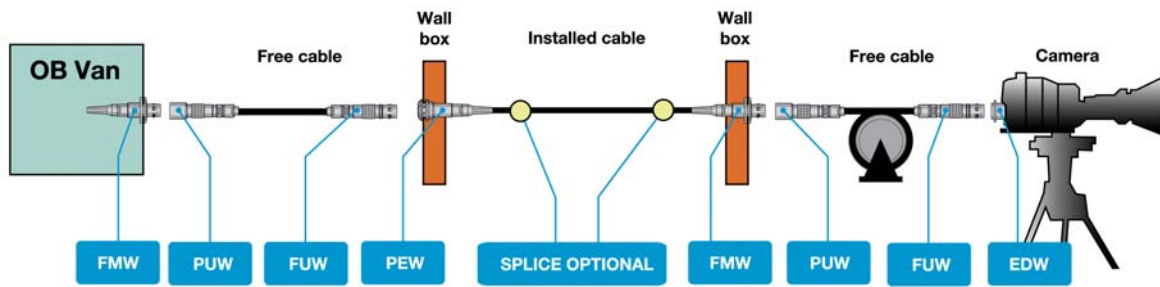

Studio

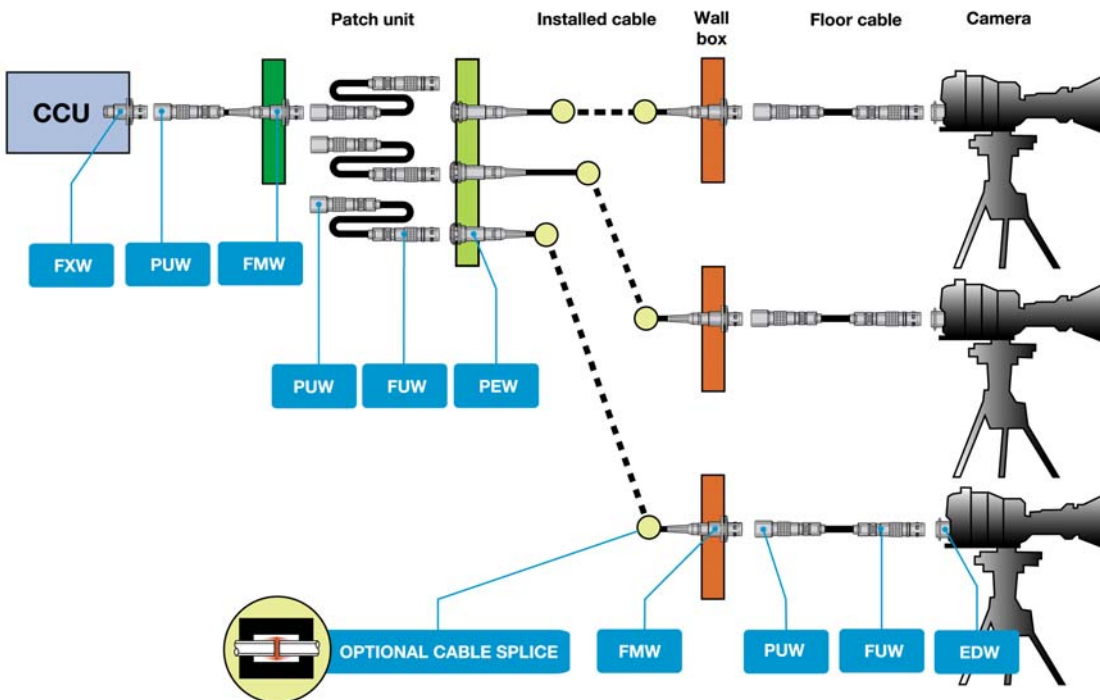

AUSTRIA

LEMO Elektronik GesmbH
Tel: (+43 1) 914 23 20
sales@lemo.at

DENMARK

LEMO Denmark A/S
Tel: (+45) 45 20 44 00
info@lemo-denmark.dk

FINLAND

LEMO Finland OY
Tel: (+358 9) 849 22 40
Email: info-fi@lemo.com

FRANCE

LEMO France Sàrl
Tel: (+33 1) 45 17 27 90
lemofran@lemo.com

GERMANY

LEMO Elektronik GmbH
Tel: (+49 89) 42 77 03
info@lemo.de

HUNGARY

REDEL Elektronika Kft
Tel: (+36 1) 284 09 46
info@lemo.hu

ITALY

LEMO Italia sri
Tel: (+39 02) 66 71 10 32
Tel: (+39 02) 66 71 10 46
lemoit@iol.it

JAPAN

LEMO Japan Ltd
Tel: (+81 3) 38 11 21 61
lemoinfo@lemo.co.jp

NORWAY

LEMO Norway A/S
Tel: (+47) 22 91 70 40

SPAIN/PORTUGAL

IBERLEMO S.A.
Tel: (+34 93) 860 44 20
info@iberlemo.es

Madrid Office
Tel: (+34 91) 469 99 19
madrid@iberlemo.es

SWEDEN

LEMO Sweden AB
Tel: (+46 8) 635 60 60

SWITZERLAND

LEMO VERKAUF AG
Tel: (+41 41) 790 49 40
info@lemo.com

USA

LEMO USA Inc.
Tel: (+1) 707 5788811
info@lemousa.com

LEMO Headquarters

SWITZERLAND**LEMO SA**

Tel: (+41 21) 695 16 00
info@lemo.com

LEMO UK Ltd

Unit 15 & 16, Hazelwood Trading Estate,
Worthing, West Sussex, BN14 8NP.
Tel: (+44 1903) 23 45 43
Fax: (+44 1903) 20 62 31
uksales@lemo.com

www.lemo.co.uk